

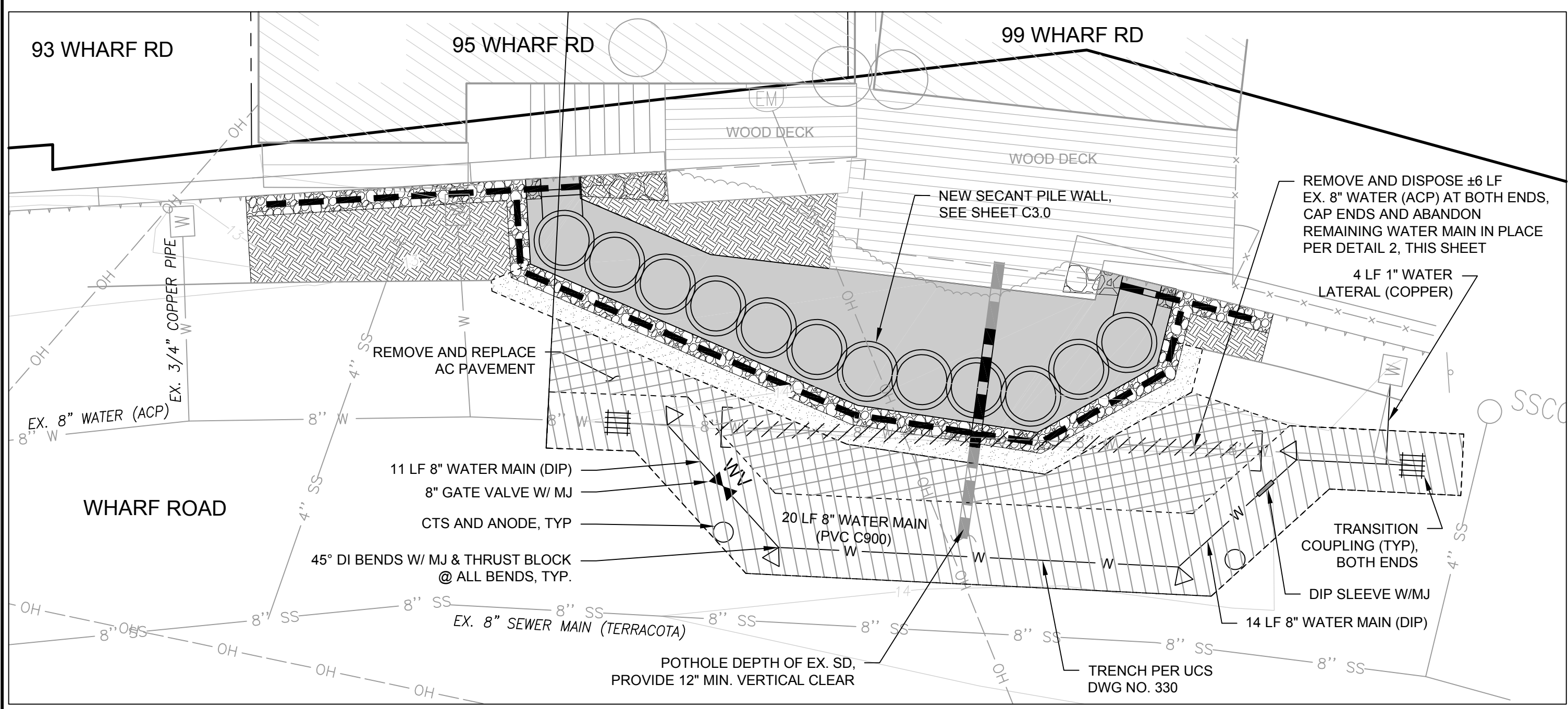

Table with 4 columns: Description, Designed, Drawn, RJS, Date, Rev, Date, 6-24-2024, BID SET

95 WHARF ROAD IMPROVEMENTS BID ALTERNATE PLAN COUNTY OF MARIN

Town Of Bolinas County Of Marin State Of California

Prepared Under the Direction of



IMPROVEMENT PLAN SCALE: 1" = 5'

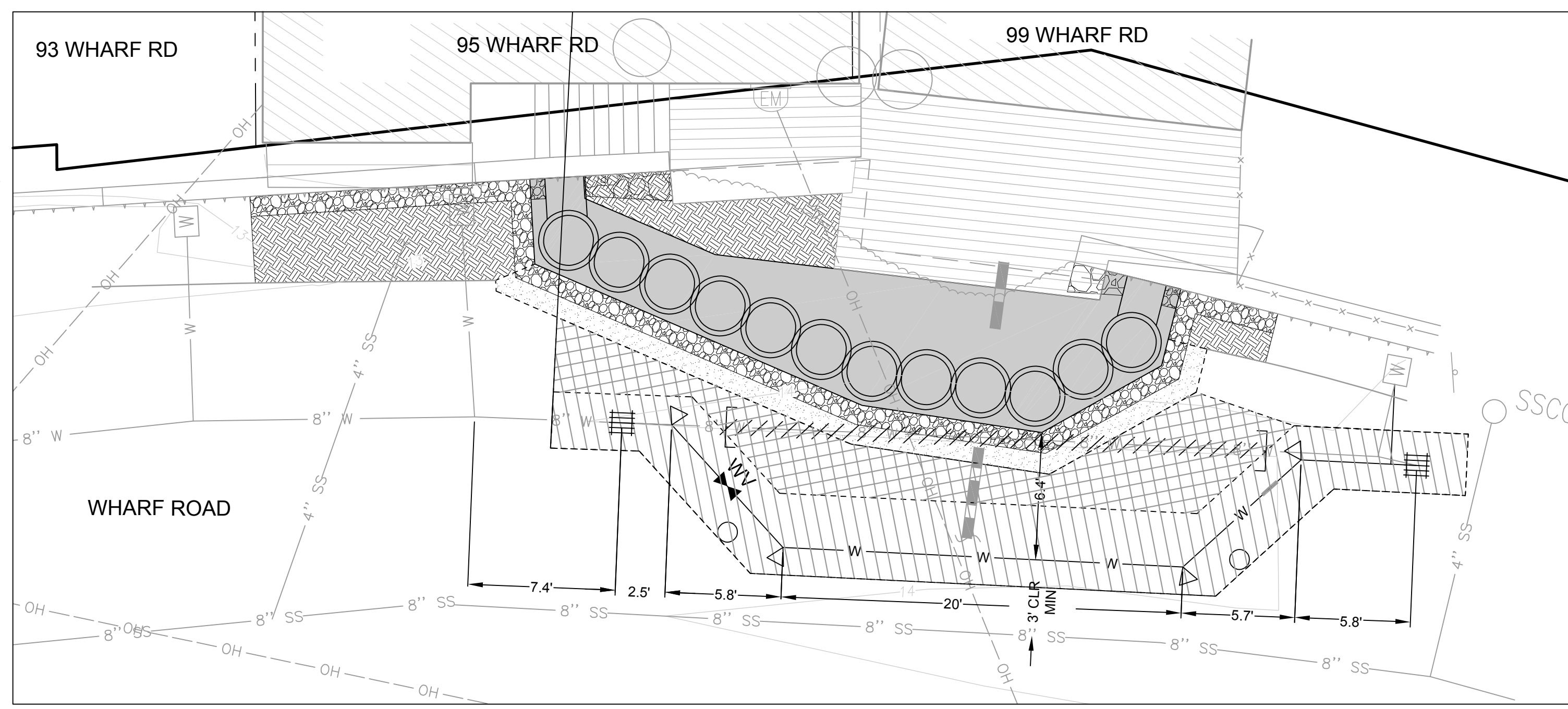

HORIZONTAL CONTROL PLAN SCALE: 1" = 5'

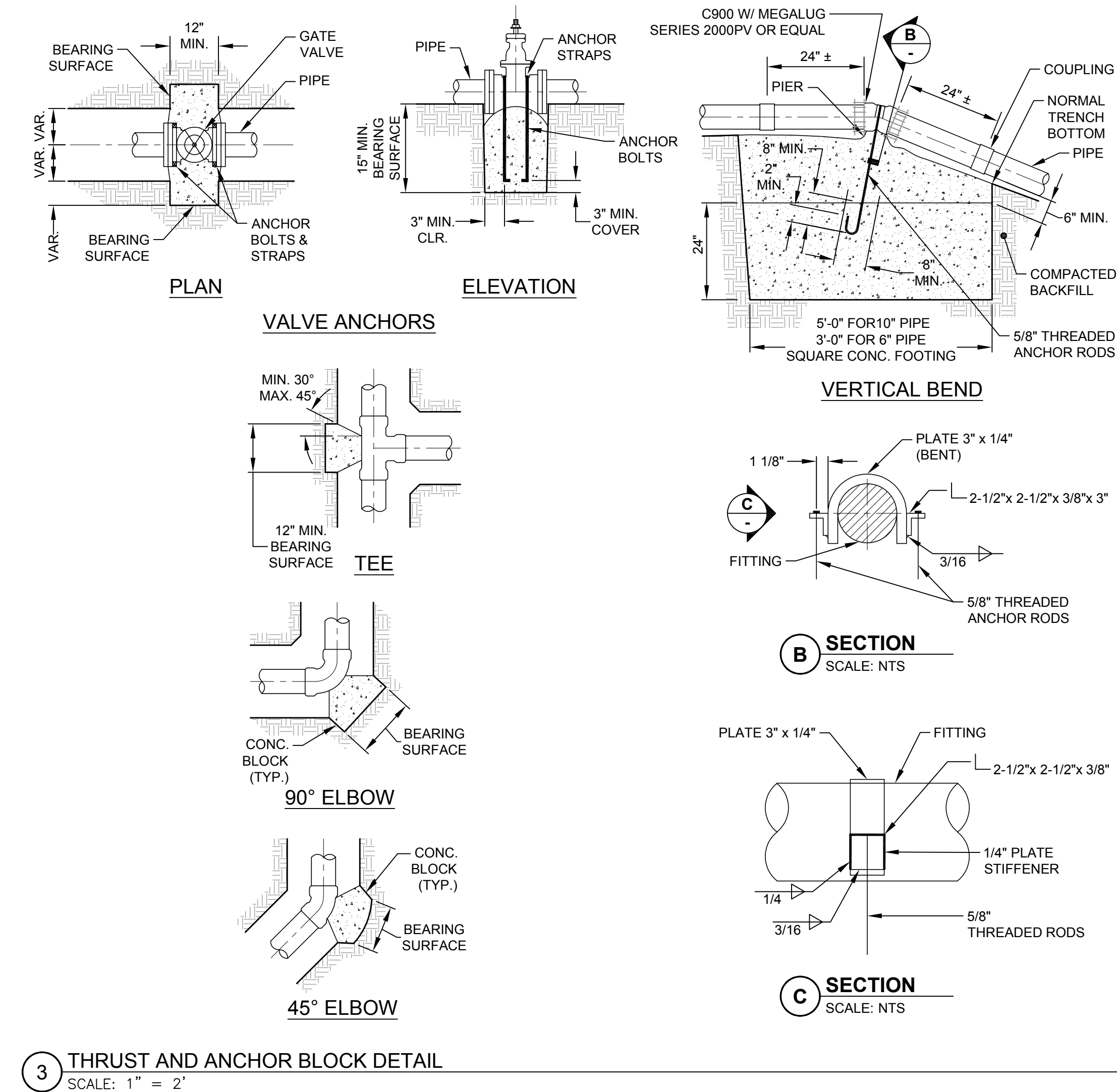
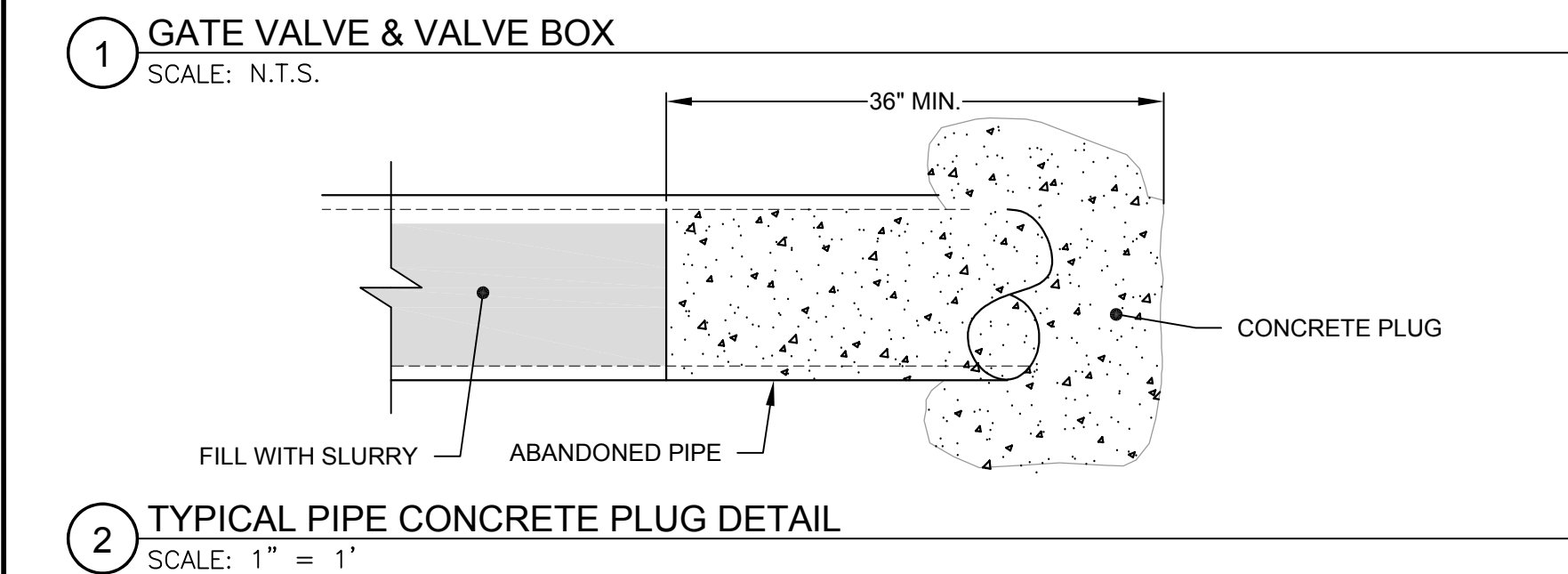
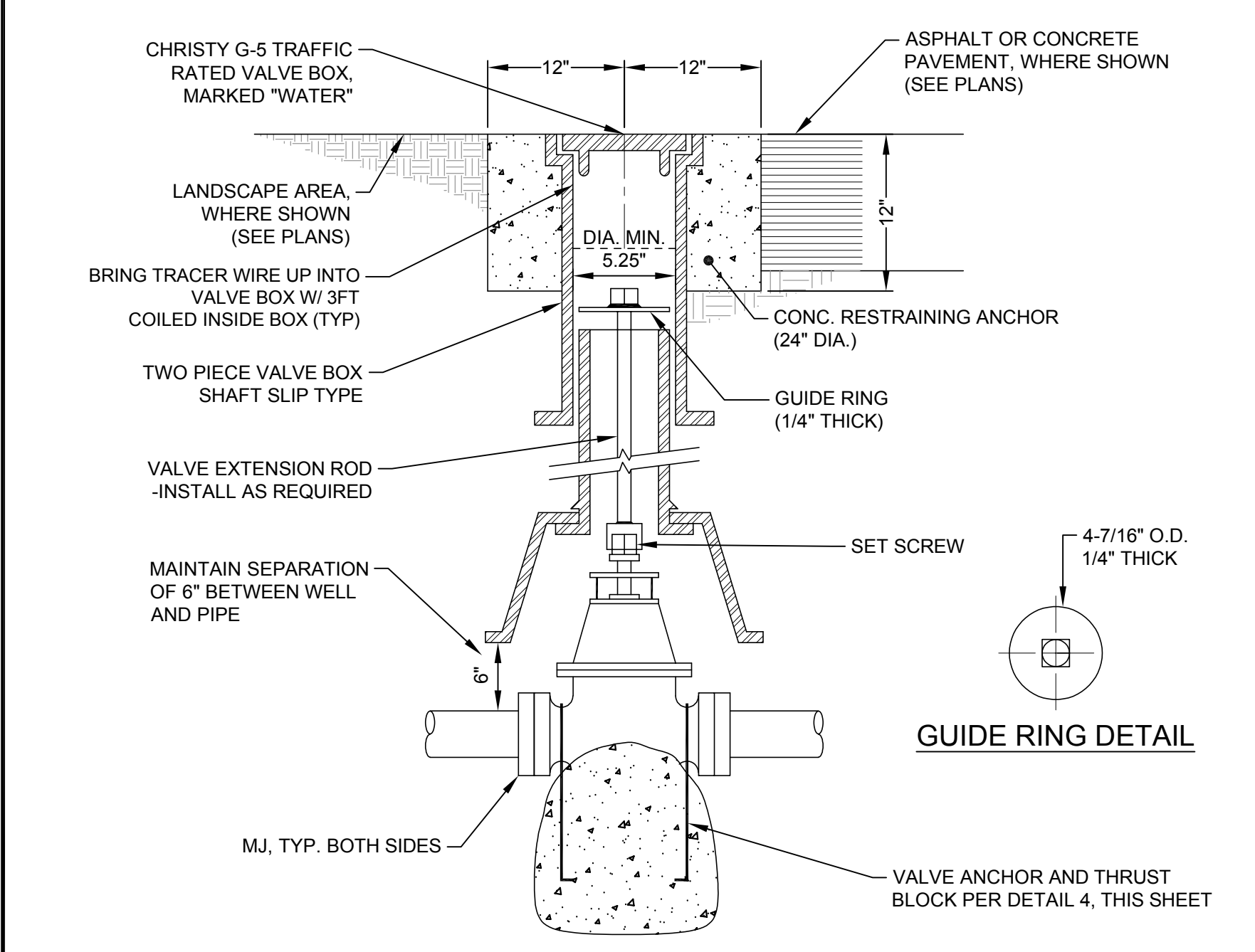
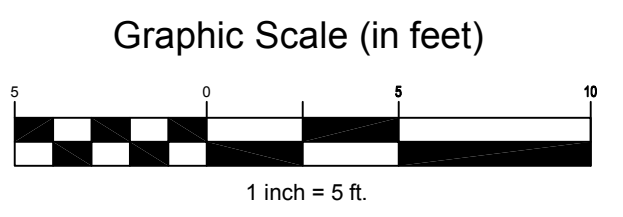

BID ALTERNATE LEGEND table with columns for symbol and description.

PIPE FITTING SCHEDULE table with columns for NO., QTY., and MATERIAL DESCRIPTION.

THRUST BLOCK BEARING AREAS - S.F. table with columns for main size, tee, bend, and bearing values.

GENERAL NOTES: 1. THRUST BLOCKS TO BE CONSTRUCTED PER N.F.P.A. 24. 2. ALL THRUST ANCHOR BLOCKS SHALL BEAR AGAINST UNDISTURBED SOIL...

GENERAL NOTES: 1. COMPLETE REPLACEMENT PIPELINE FROM MJ GATE VALVE TO THE D.I. SLEEVE LOCATION. USE D. I. CAP WITH A 2" TAP FOR TEMPORARY WATER MAIN ISOLATION...